

Medical Physics World

Bulletin of the International Organization for Medical Physics

Adhering National Organizations 1990

Argentina • Australia • Austria • Belgium • Brazil • Bulgaria • Canada • Colombia • Cyprus • Denmark • Federal Republic of Germany • Finland • France
German Democratic Republic • Ghana • Greece • Hong Kong • Hungary • India • Ireland • Israel • Italy • Japan • Korea • Malaysia • Mexico • Netherlands
New Zealand • Nigeria • Norway • People's Republic of China • Republic of the Philippines • Poland • Romania • South Africa • Spain • Sri Lanka • Sweden
Switzerland • Tanzania • Thailand • Turkey • United Kingdom • United States of America • Yugoslavia

President's Message

We are beginning a new year and a new decade. We are about to begin a new century and a new millennium. In July of this year the 16th International Conference on Medical and Biological Engineering, combined with the 9th International Conference on Medical Physics, will be held in Kyoto, Japan. The theme of this meeting will concentrate on "Important Issues for the Next Millennium." It will attempt to chart some of the directions and progress of physics and engineering as it is applied to the solution of medical problems.

Kyoto, as an ancient capital of Japan, is an excellent choice for the site of this meeting. Those of us who attend from abroad must plan to spend many extra days seeing the sights of this very special city and the country around it. We have the opportunity of learning something of old Japan and studying some of its unique history. The Kyoto International Conference Hall, the venue of the congress, is the very opposite of old. It boasts every modern congress facility that is available anywhere in the world.

I, personally, have attended and participated in other meetings in Japan, and I have no hesitation in predicting that this meeting will be a good and memorable one. I strongly recommend that all who can should attend.

On behalf of the executive staff of the IOMP I wish you all a Happy and successful New Year.

J. R. Cunningham, Ph.D., President, IOMP

Secretary-General's Report

The past six months since my last report have been most productive, as the following will demonstrate.

New Members

I am very pleased to report that the Officers have elected the following new Adhering National Organizations: Argentina, Bulgaria, Ghana and Romania. Welcome to the IOMP. These, along with other new members, will be presented to the Council in Kyoto for ratification.

Kyoto, 1991

Prof. Hiroshi Abe and all his Organizing Committee have been doing an outstanding job in preparation for our triennial World Congress in Kyoto, 7-12 July, 1991. They are to be heartily congratulated. It is clear from the 2nd Circular that our colleagues in Japan are going to be superb hosts. The scientific and social programs are excellent, and there is no doubt that Kyoto is a city not to be missed. I hope that KYOTO 1991 is a venue on your calendars.

There are four regional meetings that have been organized just before and after the Kyoto Congress. These are Seoul, Xian, Guangzhou and Sydney. Details are given in the Calendar of Events.

Libraries Program

Our Libraries for Developing Countries Program is thriving, so much so that it was simply getting too much for me to handle, so we have appointed one of my colleagues, Cathy Warmelink, Curator of the IOMP Libraries Program. Her progress report appears on page 11 in this issue. Of special significance are the following two agreements we have been able to negotiate.

IOP Publishing, Ltd.

I am very pleased to announce that we have consummated an agreement with the Institute of Physics Publishing, Ltd., which will be of enormous benefit to our developing countries program. A separate report appears on page 11 in this issue. In essence, in exchange for our agreement to make IOPP's Adam Hilger

TABLE OF CONTENTS

President's Message	1
Secretary-General's Report	1
Announcement — Gammex Companies Travel Awards	2
IOMP Corporate Members	2
Advertising Rates	2
IOMP Officers	2
Quality Assurance in Brachytherapy	4
Calendar of Events	10
Announcement — IOMP Libraries Program Update	11
Announcement — IOP and IOMP Join Forces	11
Beijing International Congress On Medical Radiation Physics, May 27-30, 1990	18

Continued on page 2

Continued from page 1

"Medical Science Series" of books "official publications of the IOMP," the IOPP will send complimentary copies of each new book in the series to 100 IOMP developing countries libraries plus an additional five books from their list of publications. Furthermore, our present 13 IOMP libraries will receive an additional 10 books each, and all IOMP members are eligible for a 20% discount on every IOPP medical physics book.

AAPM Publications

The IOMP and the AAPM, through their International Affairs Committee, have agreed to the provision of 20 complementary sets of all AAPM publications to be sent to developing countries libraries. The AAPM will provide the books and the IOMP will pay postage and packing costs. The 20 libraries will be selected by mutual agreement between their Committee and the IOMP Officers.

Kyoto Travel Grants

Applications for grants to attend the Kyoto World Congress have been overwhelming. The total funding requested exceeded our annual income about threefold. Although we wanted to honor all the applications, the Officers were forced to establish a ranking system based upon the relative merits of each application. A postal ballot was held between the Officers and the Developing Countries Committee Chairman, Prof. Xie Nan-Zhu, and this resulted in the award of grants to 12 national societies, with the top ranked society receiving 100% of the grant requested, gradually decreasing to only 15% for the lowest ranked society.

A grand total of \$23,000 U.S. has been allocated, which is almost three times that awarded to support attendance at the 1988 Congress in San Antonio. In addition, I am requesting that our Corporate Members consider their allocations of their 1991 dues to the support of further Kyoto Travel Grants. By this means we hope to be able to supplement some of the awards to the national societies that did not fare so well in the rankings above.

Colin G. Orton

Announcement

Gammex Companies Travel Awards

The Gammex Companies generously provided the IOMP with \$2,000 U.S. for 1990 to support Travel Awards to enable medical physicists from developing countries to attend international meetings. The first award was for \$500 U.S. to Mrs. A. Kalabay, a Delegate of the Medical Physics Association of Turkey, to attend the EFOMP 10th Anniversary Meeting in Oxford, September 1990. The remainder of this fund will support an attendee to the Kyoto World Congress.

Application forms for Travel Grants are available from my office.

Colin G. Orton

IOMP Corporate Members

The following corporations are Corporate Members in the IOMP for 1990:

Computerized Imaging Reference Systems
Norfolk, VA, USA

Computerized Medical Systems
Maryland Heights, MO, USA

Data Span/Gammex, Inc.
Orchard Park, NY, USA

Gammex Lasers, Inc.
Milwaukee, WI, USA

Gammex - RMI, Ltd.
Nottingham, England

Gammex - RMI S.A.

IOP Publishing, Ltd.
Bristol, England

Multidata Systems International Corp.
St. Louis, MO, USA

Nuclear Associates
Carle Place, NY, USA

Nucletron Corp.
Columbia, MD, USA

Oldelft
Delft, Netherlands

Physics Associates, Ltd.
Benicia, CA, USA

Radiation Measurements, Inc.
Middleton, WI, USA

Varian
Palo Alto, CA, USA

Funding derived from these sources is allocated to the support of hospital physicists in developing countries. Corporations wishing to receive more information about Corporate Membership should contact: Colin G. Orton, Ph.D., Prof., IOMP Secretary-General, address on elsewhere on this page.

Advertising Rates

Companies interested in advertising in future issues of MPW should contact the Editor. Deadline for the next issue is April 1, 1991. Advertising rates in U.S. dollars are:

1/6 page.....	\$265.00	1/3 page.....	\$480.00
1/5 page.....	\$320.00	1/2 page.....	\$695.00
1/4 page.....	\$375.00	1 page.....	\$1,250.00

Discounts are available for advertising in successive issues. Prime locations available at premium rates. Please write for details.

Officers of the Council/IOMP

President

John R. Cunningham, Ph.D., Prof.
960 Teron Road, Apt. 910, Kanata, Ontario K2K 2B6, Canada
Fax: (613) 592-6559

Vice President

Udipi Madhvanath, Ph.D.
Head, Division of Radiological Protection
Bhabha Atomic Research Centre
Bombay 400-085, India
Fax: 91-22-556-0750, Ref: DRP/UM/C-182/90

Secretary-General

Colin G. Orton, Ph.D., Prof.
Gershenson Radiation Oncology Center
Harper-Grace Hospitals
3990 John R, Detroit, Michigan 48201, U.S.A.
Fax: (313) 745-2314

Past President

Lawrence H. Lanzl, Ph.D., Prof.
Medical Physics, Rush-Presbyterian-St. Luke's Medical Center
1753 West Congress Parkway, Chicago, Illinois 60612, U.S.A.

Editorial Board

Richard L. Maughan, Ph.D., Editor
Gershenson Radiation Oncology Center
Harper-Grace Hospitals
3990 John R, Detroit, Michigan 48201, U.S.A.
Fax: (313) 745-2314

Geoffrey S. Ibbott, M.S., Calendar of Events Editor
Department of Therapeutic Radiology
Yale-New Haven Hospital
20 York Street, New Haven, Connecticut 06504, U.S.A.
Phone: (203) 785-3465, Fax: (203) 562-0260

Lawrence H. Lanzl, Ph.D., Prof., (ex officio)

John R. Cunningham, Ph.D., Prof., (ex officio)

Colin G. Orton, Ph.D., Prof., (ex officio)

Editorial and Business correspondence should be addressed to Dr. Richard Maughan. Events information should be addressed to Mr. Geoffrey Ibbott. IOMP correspondence should be addressed to Dr. John Cunningham and Dr. Colin Orton.

CAPINTEC.[®]

THE DOSIMETRY RESOURCE BY WHICH ALL OTHERS ARE MEASURED.

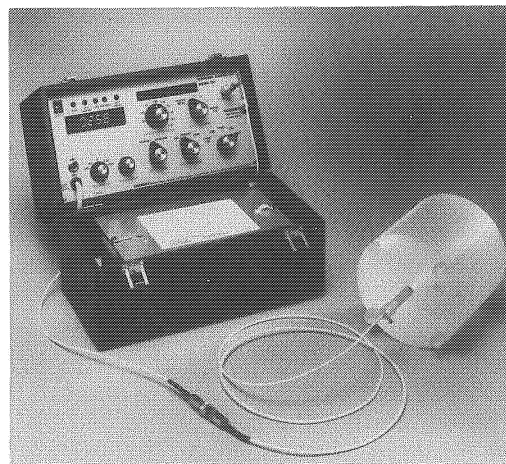
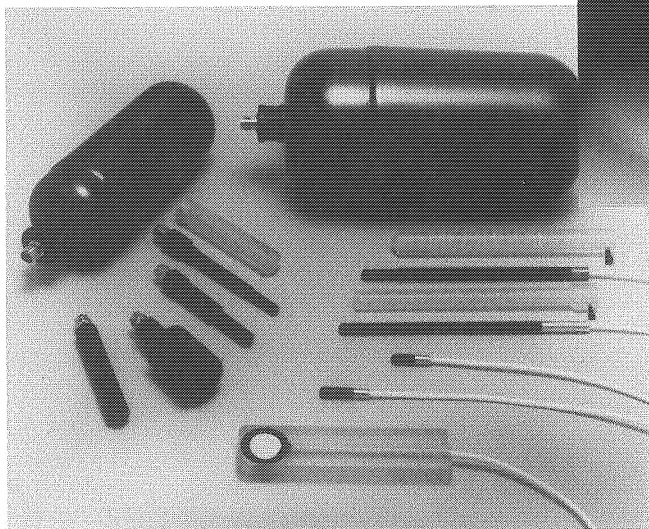

When it comes to dosimetry products and systems, think Capintec.

Only Capintec offers you a wide range of high quality products for dosimetry. Only Capintec gives you the convenience of buying from a single, trusted source. And only Capintec assures that you're getting it all at competitive prices.

Choose from a complete selection of ionization chambers and electrometers, a comprehensive family of phantoms, and from a broad variety of other dosimetry items, including our Tomorad[®] system for accurate dose measurement in computerized tomography.

For details on these or other Capintec products, call or write: Capintec, Inc., 6 Arrow Road, Ramsey, NJ 07446. Toll free (800) 631-3826 or (201) 825-9500. Telex: 642375 (CAPINTEC RASY)

EXCELLENCE IN RADIATION MEASUREMENT

***Give us a call about our new line of phantoms.**

© CII and Tomorad are registered trademarks of Capintec, Inc.

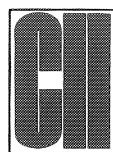

CAPINTEC, INC.

6 Arrow Road, Ramsey, NJ 07446
In N.J. (201) 825-9500 Toll Free (800) 631-3826
Telex: 642375 (CAPINTEC RASY)

Quality Assurance in Brachytherapy

Colin H. Jones, Ph.D., F.Inst. P., FIPSM

Joint Department of Physics
Institute of Cancer Research and
Royal Marsden Hospital
Fulham Road
London SW3 6JJ

I. Introduction

Brachytherapy utilizes encapsulated radioactive sources to deliver therapeutic radiation dose by surface, intracavitary or interstitial techniques. The physical aspects of brachytherapy have been discussed by numerous authors.^{1 2 3} The wide spectrum of techniques and different radionuclides used, makes brachytherapy assurance a complex subject but there are two fundamental requirements. These are:

- (1) To deliver a prescribed radiation dose within acceptable limits of accuracy; ideally, the absorbed dose in the target volume should be within 5% of the prescribed dose.⁴
- (2) To ensure that in so doing, patient, staff and public are not irradiated unnecessarily.

To achieve these objectives, every aspect of brachytherapy must be evaluated. This paper describes the principles that underpin brachytherapy quality assurance and some of the work it entails.

There are four important elements which are common to all programmes. These are:

- (1) A person experienced in radiation physics should be made responsible for drawing up the quality assurance programme and for ensuring that it is complied with.
- (2) The programme should be documented in detail; the procedures to be adhered to, the tests to be carried out, and the frequency of the tests to be undertaken should be specified; the results of all tests should be recorded in a log book.
- (3) Radioactive sources should only be used in compliance with local, or national and/or international recommendations.
- (4) Incidents which have, or might have affected the precision of treatment or the safe use of sources should be noted, so that the programme can be modified in the light of experience. The overall programme should be reviewed periodically.

The following facets of brachytherapy should be an integral part of quality assurance.

II. Source Identification and Description

Encapsulated sources with a long half life should be clearly identifiable: source markings should be recorded. A good magnifying glass and spotlight are useful for this purpose or CCTV camera with a close-up lens.

The manufacturers data sheets or test reports should be appended to local documentation. The following information should be recorded:

- (1) the radionuclide;
- (2) the activity on a given date;
- (3) the serial number or other distinguishing mark;
- (4) the date of receipt;
- (5) the normal location of the source;
- (6) the recommended working life of the source (when appropriate);
- (7) the date and manner of disposal (when appropriate).

As much information as possible should be recorded about the physical and chemical composition of the radioactive source including the presence of any radioactive impurities.

Some sources (eg Ir¹⁹²) require a storage period after initial production to allow the decay of short lived impurities: the user should ensure that such procedures are followed.

Source integrity and mechanical strength will determine how sources can be used clinically. Data sheets should include information about source encapsulation: this can affect source calibration and dosimetry, and such information might be useful in the event of source loss, mechanical or fire damage.

Sources (such as caesium needles and tubes) approaching the end of their recommended working life should be assessed to determine whether they should be replaced.

III. Source Checks

A. Leakage and Contamination Tests

Long lived brachytherapy sources are doubly encapsulated for mechanical strength and to prevent leakage of radioactive material in the event of source damage. Sources obtained from manufacturers are issued with leakage test certificates which describe the tests that have been carried out: these include immersion and wipe tests. For caesium sources manufactured in the UK, the safety level is taken to be 200Bq(5nCi). Users should be aware of the tests that have been undertaken at manufacture but should not assume that new sources are necessarily free from surface contamination. Occasionally, some manufacturers inadvertently sell a source carrying a small quantity of surface radioactivity.

New, encapsulated sources should be wiped with a swab or tissue moistened with water or ethanol and measured using a GM or scintillation counter capable of detecting 200Bq (5nCi). The method used should keep radiation exposure to a minimum; it should clean the outside of the source without causing abrasions to the source container.⁵

Continued on page 6

How will dynamic therapy change the shape of radiation oncology?

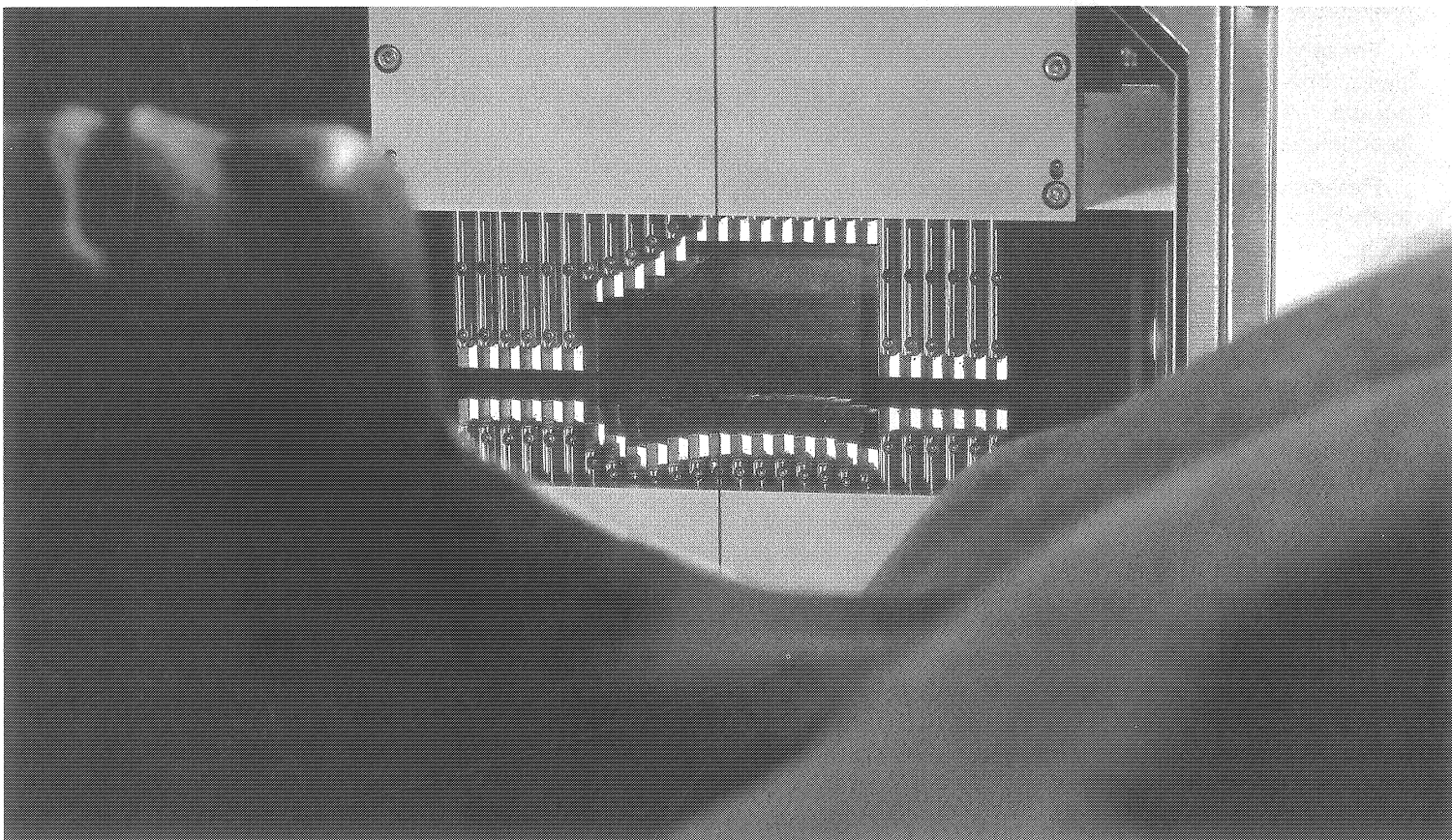

More dose where you need it. Combine computer-controlled machine parameters with Varian's multileaf collimator and increase dose to target volumes while decreasing dose to healthy, surrounding tissue.

More complex treatments in less time. Varian's research partners are finding that computer-controlled collimation reduces the need to fabricate and use cumbersome, customized blocks. This makes treating more fields per patient more practical.

Varian's independent collimators create dynamic wedge-shaped dose distributions, eliminating the need to insert mechanical

wedges, reducing setup time, and increasing operator convenience.

This adds up to dramatic improvements in productivity by delivering more precise treatments in less time with better results.

Advancing radiation therapy treatment is a top priority at Varian. For more information on how this will benefit you, your department, and your patients, please call 1-800-544-4636. Find out what you can gain from having Varian as your partner for life.

3045 Hanover Street
Palo Alto, CA 94304
1-800-544-4636

varian 

Innovative people making technology work.

The extent of leakage from a sealed non-gaseous source or leak proof container may be estimated by multiplying the total activity measured in a wipe test by a factor of ten.⁶ The source must be regarded leaking if tests indicate that there is free activity of 2kBq (50 nCi) and must be sealed immediately in an air-tight container and returned to the manufacturer.

In the case of radium where the likely leak product is radon gas, the total activity of the gas produced should be measured after immersing the source in scintillant for 12 hours: the same limit then applies. Radium sources should be tested at least annually.

For other long lived sources in clinical use, the maximum time between leakage tests should be 2 years: annual tests should be made on sources that have been in use for several years.

Flexible spring type source containers used in after-loading techniques should be swabbed annually. One method of achieving this is to use a moistened foam sponge filter through which the source passes as it is removed from its storage safe.

In the case of beta ray sources such as Sr⁹⁰/Y⁹⁰ ophthalmic applicators special care must be taken because the surface of the applicator is particularly delicate. Leak tests must be performed at least annually.

B. Autoradiography and Radiography

These techniques can be used conjointly or separately to provide information about the distribution of radioactive material within its container, and positional information about individual sealed sources in radioactive source trains.

Autoradiography is useful for checking the uniformity of wire sources and ribbons of radioactive seeds. When radioactive wires are cut, it provides a means of recording particulate contamination.

Manufacturers often provide autoradiographs with sources (e.g. caesium tubes, needles) but users should autoradiograph newly acquired sources.

The technique is simplified by having a support which has a recess the same dimensions as the source: uniform pressure should be maintained over the film (envelope wrapped) and source to keep both in close contact. Autoradiographs should be evaluated to confirm that the source activity is distributed uniformly.

Needle sources might have two or more cells: the source activity and distribution in each cell should be the same, unless one or more of the cells is deliberately loaded differentially.

Autoradiography and radiography should be used to check the configuration of single and multiple sources in pre-loaded source trains. In the case of afterloading machines whose source configuration can be pro-

grammed, autoradiographic checks should be carried out at commissioning, and after machine service or catheter replacement to ascertain the precise location of each source and the integrity of software and machine function.

Applicators into which sources are loaded, either by hand or automatically by machine should be checked by autoradiography before being put into clinical use and thereafter annually. Moulded wax is useful for positioning and supporting the applicators. Lead foil markers embedded into the surface of the wax can be used to provide identification marks and scales which are imaged on film by electron emission. The method allows precise comparisons to be made of different applicators and provides a radiographic record of the location of the radioactive sources inside loaded applicators.⁵

The maximum difference in source position within a set of applicators should be less than $\pm 2\text{mm}$.⁷ Radiographic markers are used in applicators for dosimetry purposes should be imaged by X-ray to provide data to correlate the geometrical markers with source positions. Marker positions should vary less than 1mm in applicators of the same dimensions.

C. Calibration of Brachytherapy Sources

The strength of a brachytherapy source should be specified in terms of the air kerma rate at a point in free space at a distance of 1m from the source on the radial plane of symmetry (i.e. the plane bisecting the active length and the cylindrical axis of the source). In the case of a wire source the output should be specified for a 10mm length.⁸ This specification avoids errors that might arise from using incorrect values for specific gamma ray constants, exposures rate constants and inaccuracies in calculating or estimating filtration corrections for individual sources. The recommended units for air kerma rate are micrograys/hour ($\mu\text{Gy h}^{-1}$): an air kerma of 1 Gy is equivalent to an exposure of 114.5R. Some manufacturers calibrate in terms of activity, nominal activity or equivalent activity (in Bq or Ci). In these circumstances it is essential that the user knows how the manufacturer has derived the value specified.

Before being used clinically, sources should be calibrated by the user. The preferred measurement device is a re-entrant ionisation chamber (i.e. an isotope calibrator). In the case of high activity sources accurate calibration can also be achieved with an ion chamber. The calibration of both these instruments should be traceable to a national standards laboratory: this is most readily achieved with the aid of one or more radioactive sources calibrated at the national standards laboratory.

Therapy Beam Evaluation from Keithley.

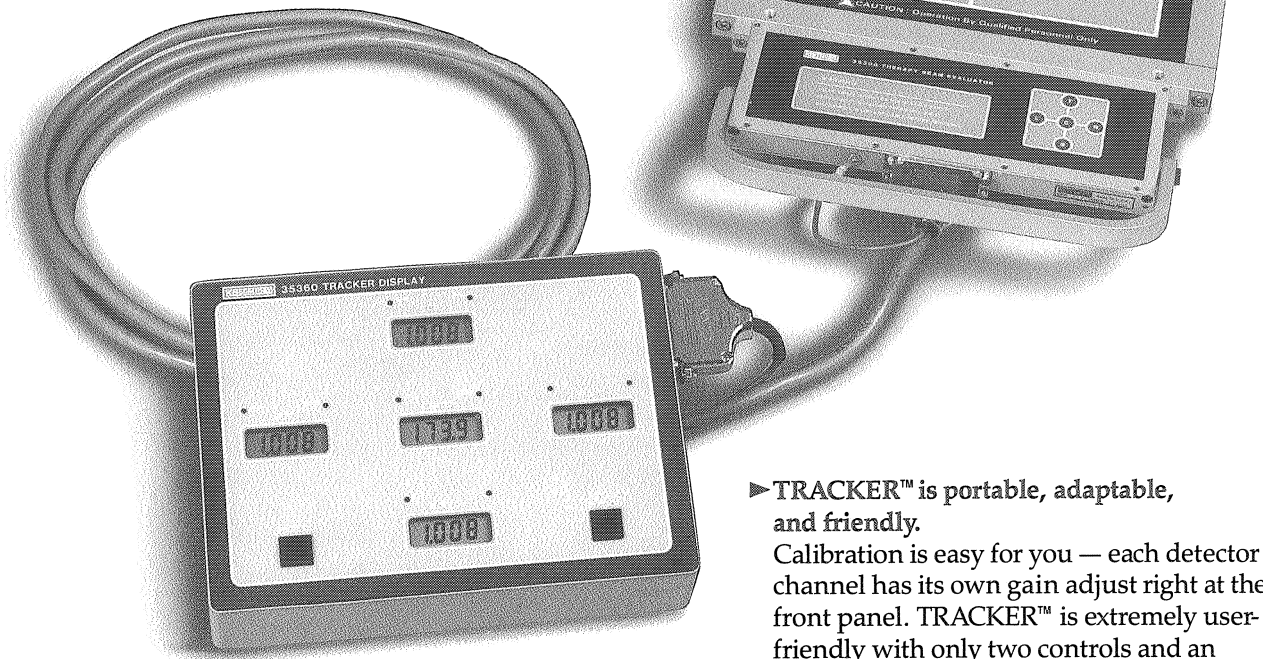

**Direct readout
for your technician.
No training required.**

- ▶ **TRACKER™ Display / Model 35360 for daily checks.**
Daily constancy checks for your linac are quick and easy with Keithley's TRACKER™ Display / Model 35360. Use TRACKER™ measurements for beam flatness and symmetry calculations. Add an energy constancy option for more capability.

TRACKER™ features a direct readout from five ion chamber detectors. This allows ratios-to-center from the four peripheral chambers to the center chamber. Each chamber has its own electrometer / channel and display. This configuration provides excellent chamber / field correlation.

- ▶ **TRACKER™ is portable, adaptable, and friendly.**

Calibration is easy for you — each detector channel has its own gain adjust right at the front panel. TRACKER™ is extremely user-friendly with only two controls and an automatic reset. For the technician who must check several therapy units, the portable TRACKER™ is powered with rechargeable batteries for quick set-up with no line cords. And of course, it's completely compatible with — and can be added to — all TRACKER™ units currently in use.

- ▶ **TRACKER™ is friendly to your computer, too.**

TRACKER™ is easily interfaced to your computer for measurements, calculations and database.

Call, write, or fax us for more information about TRACKER™. Your technician will love it.

Only from Keithley.
The measure of quality.

KEITHLEY

Keithley Radiation Measurements Division
Keithley Instruments, Inc.
28775 Aurora Road
Cleveland, Ohio 44139 U.S.A.
(216)248-0400 Telex 205124
FAX (216)349-2307

The re-entrant ionisation chamber should respond linearly throughout its measuring range: its energy response must be known and care must be taken to ensure that when measuring high activities there is no drop in sensitivity. Before use, the dependence of the chamber sensitivity on the radionuclide, the position of the source within the chamber and the length of the source should be investigated. The response of the chamber will also be dependent upon the source filtration and encapsulation.

The calibration method will depend on the radionuclide and its activity: one or more long-lived calibrated sources will be required depending upon the range of isotopes being used. Chamber calibration checks should be made every six months. A perspex source holder should be used to ensure that sources are measured at the same position in the chamber.

Ion chambers can also be used for calibrating radioactive sources but special care has to be taken to correct for the effects of radiation scatter, the chamber volume and the physical size of the radioactive source. To measure low air kerma rates requires a large volume chamber (typically 30-100cm³), and it is often difficult to achieve an adequate signal to noise ratio (better than 100:1) at a distance of 20-100 cm or more from the source. Furthermore it is essential to be able to reproduce accurately the positioning of the standard source and all other sources to be measured. These problems are less significant when the air kerma rate is high.

Air kerma rates (and/or source activity) should be measured and compared with the manufacturers test report: discrepancies greater than the accuracy limits specified by the manufacturer should be explored further.

D1. Long Half-Life Sources of Low Activity (Ra²²⁶, Cs¹³⁷, Co⁶⁰ etc.)

Ideally, the user should have calibrated standard sources for each radionuclide to be measured and each type of source. This is rarely possible and if the user has only one calibrated source, correction factors have to be used to allow for the energy response of the re-entrant ion chamber,¹¹ variation in source geometry and any differences in source encapsulation.⁹ The appropriate standard should be used to calibrate all other similar sources. This is best achieved by sequential placement of the standard source and the source to be calibrated in the same position in the re-entrant ion chambers and can be achieved with the aid of a perspex holder to locate the source centrally.

The dose rate from individual sources (eg Cs¹³⁷) should be determined within 5%. Corrections for radioactive decay should be made at suitably frequent intervals: the frequency recommended is every month for Co⁶⁰ sources and twice a year for Cs¹³⁷ sources. For

Ir¹⁹² and I¹²⁵ sources the correction for radioactive decay both up to the time of use and during treatment should be part of the treatment planning.

D2. Sources Used in Automatic Afterloading Systems (Cs¹³⁷, Ir¹⁹² etc.)

- (i) Pre-loaded source trains (e.g. Curietron sources). The manufacturer should guarantee that the output of each source loaded into the source train does not differ by more than 5% from that stated. When possible the user should confirm the position of individual sources in a source train by means of autoradiography and radiography (see 3.2) and check the isodose pattern for each train using film, thermoluminescent dosimeters, an ion chamber or a solid state detector. The location and relative activity of individual sources along a source train can also be recorded by means of a device employing a highly collimated detector.¹⁰
- (ii) Multiple sources of similar activity (e.g. Cs¹³⁷ Selectron sources). Upon receipt the variation in activity between individual sources should be ascertained with a re-entrant ion chamber.¹¹ The variation in activity of individual sources should be less than 5%. The user should request a certificate of the homogeneity of the source activities from the manufacturer.¹² The weighted mean air kerma rate should be determined.
- (iii) Single high dose rate sources. The air kerma rate of a high activity source at 150mm is typically 1-2Gy/h. This can be measured with a small volume ion chamber (0.1 to 0.6cc) in air with a reproducibility of 1% and an uncertainty of better than 5%. When the physical dimensions of the source and chamber are small an accuracy can be achieved similar to that obtainable in teletherapy.¹³ Before being used clinically new sources should be calibrated from two independent sets of measurements. The dose rate of sources in use should be checked at least every month.

D3. Short Half Life Sources of Low Activity (e.g. Au¹⁹⁸, Ir¹⁹², I¹²⁵)

- (i) A long half life source as a reference should be identified.
- (ii) Obtain a calibrated standard source of the appropriate short lived isotope and compare this with the reference source by sequential placement within the re-entrant ion chamber using the same chamber settings. In this way determine the relative sensitivity of the system to the two sources. The chamber can then be calibrated for the particular radionuclide and the long lived reference source used to verify that the chamber is operating properly after the short half life source has decayed away.

Continued on page 12

OUTPATIENT BRACHYTHERAPY TREATMENT

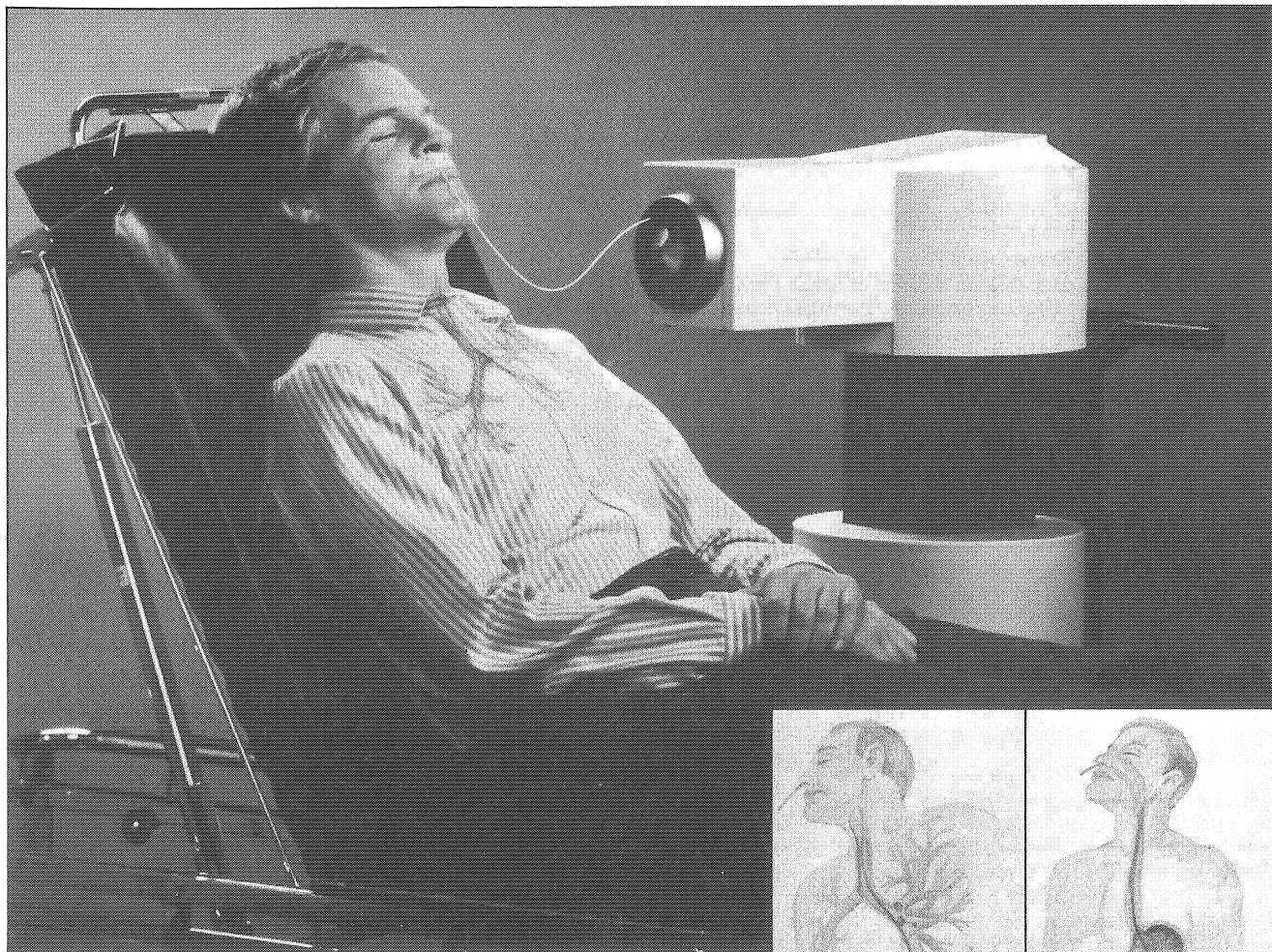

MicroSELECTRON-HDR 192Ir

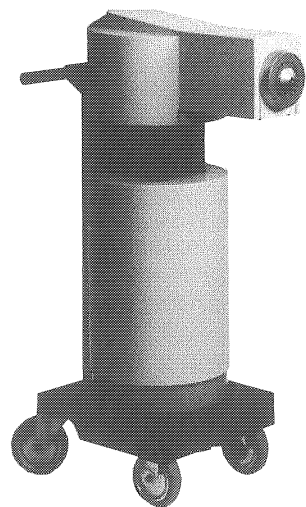

The microSelectron HDR is a high dose rate interstitial and intraluminal remote afterloading system. It consists of a treatment unit in which a single high intensity iridium source is stored within a shielded safe. The source can be remotely afterloaded into a small catheter (<2 mm) for treatment of bronchial and oesophageal carcinoma, or into an 18-channel indexing system, for high dose rate interstitial implants. The system has a microprocessor control unit with a memory for 100 standard treatments. The time is automatically corrected for the source decay.

A unique feature is an integrated simulator source used to check the system and applicator(s) before the active source leaves the safe. It also helps the therapist to set up or check the programmed source movements in the patient.

Treatment sites

Although principally designed for bronchial treatments the microSelectron HDR is also used for the treatment of: bile duct, bladder, brain, breast, cervix, endometrium, head and neck, intra operative, nasopharynx, oesophagus, prostate, rectum and others.

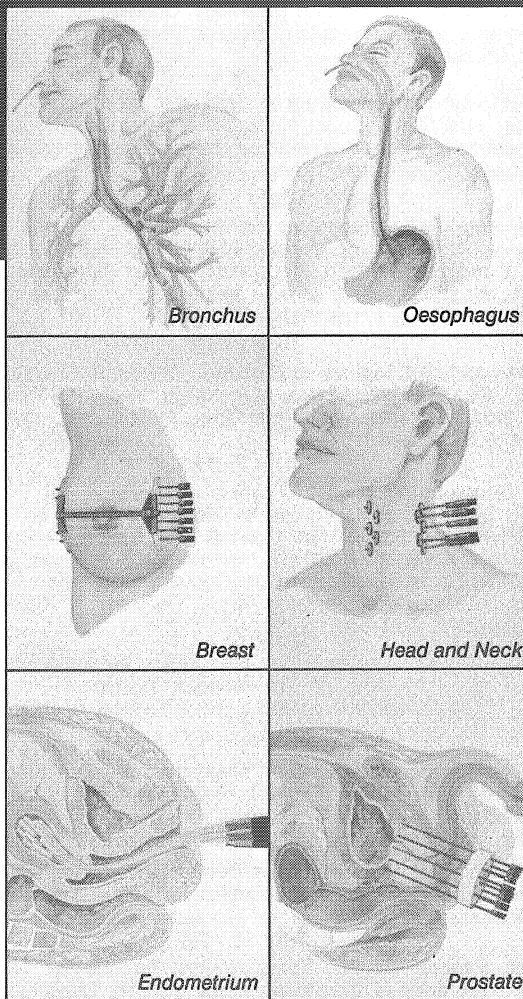

nucletron[®]

Nucletron Corporation, 9160 Red Branch Road
Columbia MD 21045, Phone (301) 964-2249
Fax (301) 964-0912, Telex via WUI 650/26117 69

CALENDAR OF EVENTS

Geoffrey S. Ibbott, Editor

1991

June 10 - 14

5th IRPS International Symposium on Radiation Physics, (ATLAS — Congress Department, ISRP-5 Lastovska, 23, Yugoslavia, [(41) 525-333 or (41) 231-555, Telex: 22413, Fax: (41) 335-977]).

June 11 - 14

38th Annual Meeting of the Society of Nuclear Medicine, Cincinnati Convention Center, Cincinnati, Ohio (The Society of Nuclear Medicine, Department of Marketing Services, 136 Madison Avenue, New York, New York 10016-6760, U.S.A. [212-889-0171]).

June 16 - 23

Annual Meetings of Canadian Organization of Medical Physicists, Canadian College of Physicists in Medicine, Canadian Radiation Protection Association and Campus Radiation Safety Officers, Winnipeg, Manitoba (Mr. Danny Buksak, The University of Manitoba, 191 Frank Kennedy Building, Winnipeg, Manitoba R3J 2N2, Canada [204-474-6633; Fax: 204-275-5863]).

June 20

Symposium on Radiation Protection, Jointly sponsored by COMP, CCPM, CRPA and CRSO, Winnipeg, Manitoba (Mr. Danny Buksak, The University of Manitoba, 191 Frank Kennedy Building, Winnipeg, Manitoba R3J 2N2, Canada [204-474-6633; Fax: 204-275-5863]).

July 3 - 6

Computer Assisted Radiology (CAR '91), Berlin, Germany, Co-sponsored by Society for Computer Applications in Radiology, (Prof. Heinz U. Lemke, c/o Univ. Klinikum Rudolf Virchow-Wedding, Altes Rontgenhaus - Raum 1005, Augustenburger Platz 1, D-1000 Berlin 65, Germany).

July 3 - 6

International Meeting on Fully Three-Dimensional Image Reconstruction in Nuclear Medicine and Radiology, Corsendonk, Belgium (Miss M. Goeman, Vrije Universiteit, Brussel, Dienst, ELEM, Pleinlaan 2, B-1050, Brussel, Belgium).

July 4

Seoul International Workshop on MRI and Radiotherapy Treatment Planning, Hotel Lotte, Seoul, Korea (Wee-Saing Kang, Ph.D., Dept. of Therapeutic Radiol., Seoul National Univ. Hosp., #28 Yeongeondong, Chongnogu, Seoul, 110-744, Korea).

July 5 - 6

2nd International Symposium on Biophysical Aspects of Auger Processes, University of Massachusetts, Amherst, Massachusetts, U.S.A. (Dandamudi V. Rao, Ph.D., Professor of Radiology, University of Medicine and Dentistry of New Jersey, 185 South Orange Avenue, Newark, New Jersey 07103-2757, U.S.A.).

July 7 - 12

9th International Congress of Radiation Research, Sheraton Center, Toronto, Ontario, Canada (Ms. Meg Keiser, Radiation Research Society, 1101 Market Street, 14th Floor, Philadelphia, Pennsylvania 19107, U.S.A. [215-574-3153]).

July 7 - 12

World Congress on Medical Physics and Biomedical Engineering: the 9th International Congress of Medical Physics and the 16th International Conference on Medical and Biological Engineering, (Dr. Hiroshi Abe, President 9th International Congress of Medical Physics, C/O Japan Convention Services, Inc., Kansai Branch, Sumitomo Seimei Midosuji Bldg., 4-14-3 Nishitemma, Kita-ku, Osaka 530, Japan).

July 7 - 12

12th International Conference on Information Processing in Medical Imaging, Wye, England (Dr. D. Hawkes, Division of Radiological Sciences, UMDS, Guy's Hospital, London Gridge, London SE1 9RT, England).

July 15 - 17

Asian and Pacific Conference on Medical Physics, Guangzhou, PRC (Prof. Xie Nan-Zhu, Medical Physics Department, Guangzhou Medical College, Dongfengzi Road, Guangzhou, PRC).

July 15 - 18

Appropriate New Technology for Developing Countries, Xian, PRC (Prof. Huang Ye-cho, Dept. of Biomedical Engin., Xian Medical Univ., Xian, Shaanxi 710061, PRC).

July 15 - 19

A.A.P.M. Summer School: Specifications, Acceptance Testing and Quality Assurance of Diagnostic X-Ray Imaging Equipment, University of California, Santa Cruz, California (AAPM, 335 East 45th Street, New York, New York 10017, U.S.A. [212-661-9404]).

July 21 - 25

Health Physics Society Annual Meeting, Columbus, Ohio, U.S.A. (Health Physics Society, 8000 Westpark Drive, Suite 400, McLean, VA 22101, U.S.A.).

July 21 - 25

American Association of Physicists in Medicine, 33rd Annual Meeting, San Francisco, California, U.S.A. (AAPM, 335 East 45th Street, New York, New York 10017, U.S.A.).

July 21 - 26

35th Annual International Technical Symposium on Optical and Optoelectronic Applied Science and Engineering, San Diego, CA (SPIE, P.O. Box 10, Bellingham, WA 98227-0010, U.S.A. [206-676-3290]).

July 22 - 25

14th Annual Conference of the Australasian College of Physical Scientists in Medicine, University of New South Wales, Sydney, Australia (Secretariat, EPSM 91 Conference, The IPACE Institute, P.O. Box 1, Kensington, NSW, 2033 Australia [Tel: 02 697-3175; Fax: 02 662-6983]).

September 2 - 5

5th Breast Cancer Working Conference, EORTC Breast Cancer Co-operative Group, Pauscollege Leuven, Belgium (Department of Radiotherapy, University Hospital, St. Rafael, Capucijnenvoer 33, 3000 Leuven, Belgium [Tel: 32 16 21 22 11; Fax: 32 16 21 22 28]).

September 2 - 6

6th Meeting World Federation for Ultrasound in Medicine and Biology, Copenhagen, Denmark (Soren Hanke, Ultralydlaboratoriet, Kobenhavns Amts Sygehus, Gentofte, DK-2900 Hellerup, Denmark).

September 2 - 6

Leuven, Belgium, Inter-Regional Seminar on Radiotherapy Dosimetry, (Conference Service Station, IAEA, P.O. Box 100, A-1400 Vienna, Austria).

September 8 - 14

International Conference on Magnetism, United Kingdom (The Meetings Officer, The Institute of Physics, 47 Belgrave Square, London SW1X 8QX, United Kingdom [01 235 6111]).

September 9 - 13

Dosimetry Course, Jointly Organized by the ESTRO and the International Atomic Energy Agency (IAEA), Vienna. Leuven, Belgium (ESTRO Secretariat, U.Z., St. Rafael, Department of Radiotherapy, Capucijnenvoer 35, 3000 Leuven, Belgium).

September 13 - 16

3rd International Conference on Radioactive Waste Management, Winnipeg, Manitoba, Canada (P. D. Stevens-Guilli, Ontario Hydro, 700 University Avenue, Toronto, Ontario M5G 1X6, Canada).

September 15 - 20

ECR '91: 7th European Congress of Radiology, Austria Center, Vienna, Austria (Mrs. Sylvia Altermann, Vienna Medical Academy, Alser Strasse 4, 1090 Vienna, Austria [Tel: 43-222 421383; Telex: 134743 medak a]).

September 16 - 20

ESTRO Teaching Course on Radiation Physics for Clinical Radiotherapy, Leuven, Belgium (ESTRO Secretariat, U.Z., St. Rafael, Department of Radiotherapy, Capucijnenvoer 35, 3000 Leuven, Belgium).

September 18 - 21

Annual Meeting of the Royal College of Radiologists, Warwick, United Kingdom (The Conference Officer, The Royal College of Radiologists, 38 Portland Place, London W1N 3DG, United Kingdom).

September 23 - 26

Computers in Cardiology 1991, Venice, Italy (LADSEB-CNR, Corso Stati Uniti 4, 35020 Padova, Italy).

September 30 - October 3

25th Anniversary Conference of the Radiation Protection Association, Aix-La-Chapelle, Germany (Strahlenschutz, Forschungszentrum Julich GmbH, Tagungsburo, Postfach 1913, D-5170 Julich, Germany [Tel: 02461/61-3833; Fax: 02461/61-4666]).

October 5 - 9

ESTRO Teaching Course in "Basic Clinical Radiobiology," Athens, Greece, Director: G. G. Steel (ESTRO Secretariat, University Hospital, St. Rafael, Radiotherapy Department, Capucijnenvoer 35, 3000 Leuven, Belgium [Tel: 32 16 21 22 13; Fax: 32 16 21 22 28]).

October 7 - 18

2nd International Workshop on Radon Monitoring in Radioprotection and Earth Science, Miramare (Trieste), Italy (ICTP, P.O. Box 586, I. 34 100 Trieste, Italy [Tel: (040) 22401; Fax: (040) 22 41 63]).

October 9 - 12

International Symposium on Luminescent Detectors and Transformers of Ionizing Radiation — LUMDETR '91, Riga, Latvia (Dr. I. Tale, Institute of Solid State Physics, University of Latvia, 8 Kengaraga St., 226063 Riga, Latvia (Tel: 013-2-260639; Fax: 013-2-225039; Telex: TEMA 161172 SU)).

October 14 - 17

ESTRO Radiation Physics Meeting, Budapest, Hungary (ESTRO Secretariat, University Hospital, St. Rafael, Department of Radiotherapy, Capucijnenvoer 35, 3000 Leuven, Belgium [Tel: 32-16 21 22 13; Fax: 32-16 21 22 28]).

October 21 - 24

3rd Conference on Radiation Protection and Dosimetry, Orlando, Florida, U.S.A. (Dr. C. S. Sims, ORNL, P.O. Box 2008, Oak Ridge, Tennessee 37831-6379, U.S.A.).

October 24 - 26

ESO Radiotherapy Course: "Hyperthermia in Clinical Oncology," Trento, Italy. Chairpersons: R. Valdagri and J. Overgaard. (ESTRO Secretariat, University Hospital, St. Rafael, Department of Radiotherapy, Capucijnenvoer 35, 300 Leuven, Belgium. [Tel: 32-16 21 22 13; Fax: 32-16 21 22 28]).

October 27 - 31

ECCO 6/ESTRO 10, Firenze, Italy (ESTRO Secretariat, U.Z. St. Rafael, Department of Radiotherapy, Capucijnenvoer 35, 3000 Leuven, Belgium).

October 31 - November 3

13th Annual International Conference on Engineering in Medicine and Biology, Lake Buena Vista, Florida (Institute of Electrical and Electronics Engineers, Dr. Joachim H. Nagel, University of Miami, P.O. Box 248 294, Coral Gables, Florida 33124, U.S.A. [Tel: 305-284-2442]).

November 3 - 8

American Society for Therapeutic Radiology and Oncology, Fontainebeau Hilton, Sheraton Washington, Washington, D.C. (American Society for Therapeutic Radiology and Oncology, 1101 Market Street, 14th Floor, Philadelphia, PA 19107-2990, U.S.A. [215-574-3180]).

November 10 - 15

Winter Meeting of the American Nuclear Society, San Francisco, California, U.S.A. (Meetings Department, American Nuclear Society, 555 Kensington Avenue, LaGrange Park, Illinois 60525, U.S.A.).

November 16 - 20

ESTRO Teaching Course on "The Role of Radiology in the Management of Cancer," Granada, Spain, Director: T. Landberg (ESRTO Secretariat, University Hospital, St. Rafael, Department of Radiotherapy, Capucijnenvoer 35, 3000 Leuven, Belgium [Tel: 32 16 21 22 13; Fax: 32 16 21 22 28]).

November 17 - 20

15th Symposium on Computer Applications in Medical Care, Sheraton Washington Hotel, Washington, D.C., U.S.A. (The George Washington University Medical Center, Office of Continuing Education, 2300 K Street, N.W., Washington, D.C. 22037, U.S.A.).

December 1 - 6

Joint Meeting of AAPM with the Radiological Society of North America, Chicago, Illinois, U.S.A. (AAPM, 335 East 45th Street, New York, New York 10017, U.S.A. [212-661-9404]).

December 14 - 18

6th Asian Oceanian Congress of Radiology, New Delhi, India (Dr. Diwan Chand Aggarwal, Imaging Research Centre, 10-B, Kasturba Gandhi Marg, New Delhi-110 001, India [3329887, Telex: 3165141, Fax: 3324652]).

1994

August 20 - 26

World Congress on Medical Physics and Biomedical Engineering: 10th International Congress of Medical Physics and 17th International Conference on Medical and Biomedical Engineering, Rio de Janeiro, Brazil.

Readers are invited to send to the Calendar of Events Editor, Geoffrey S. Ibbott, M.S. (address on page 2), information on any events not listed in this issue of MPW and also additions or corrections to the items that are listed. Officers of national societies are especially encouraged to submit information on their future national meetings.

Announcement

IOMP Libraries Program Update

At this time, the active IOMP library list totals 16! Thanks to the generous donations of books and journals by the IOPP, IPSM, AAPM, Nucletron, and the individuals listed below, we have been able to get these libraries off to a healthy start. The list of countries requesting donations is rapidly growing as well, and we hope to provide then with quality reference materials. In addition, an effort is being made to reduce the shipping costs to the recipient libraries by using their embassies and/or consulates in the U.S. and the Smithsonian International Exchange Service. These routes not only save money for the IOMP but are much quicker mailing methods.

If you would like to donate or receive any reference materials relating to medical or health physics, please Contact me at: Gershenson ROC, Harper Hospital, 3990 John R, Detroit, Michigan 48201, USA.

DONORS

Mr. Andrew Black — USA
Dr. Ramesh Chandra — USA
Mr. Gary Ezzell — USA
Dr. John Haybittle — UK
Dr. Kurt Liden — Sweden
Mr. Ralph Lieto — USA
Ms. Carmen Mesina — USA
Dr. Colin Orton — USA
Dr. Andrea Penfold — UK
Dr. Brian Stedeford — UK
Dr. Andres van Aswegen —
South Africa
Dr. Rune Walstam — Sweden

Ms. Cathy Warmelink — USA

Cathy Warmelink, MS

Curator, IOMP Libraries Program

LIBRARIES

Alger, Algeria
Alexandria, Egypt
Bogota, Colombia
Calcutta, India
Jaipur, India
New Delhi, India
Sriangar, India
Vellore, India
Bandung, Indonesia
Nairobi, Kenya
Kuala Lumpur, Malaysia
Enugu, Nigeria
Guangzhou, People's
Republic of China
Manila, Philippines
Baia-Mare, Romania
Tunis, Tunisia

Announcement

IOP and IOMP Join Forces

The IOMP aims to help promote the growth of medical physics in developing countries under the terms of a new agreement with the publishing division of the British Institute of Physics (IOP).

IOP publishes a wide range of research journals (including *Physics in Medicine and Biology*, an official IOMP publication) and has an extensive programme of book publishing under its Adam Hilger book imprint. The Medical Physics Handbooks (Series Editor Professor J. M. A. Lenihan) are well known to many readers of *MPW*. In recent years Hilger has maintained its strength in medical physics publishing with the development of the Medical Science Series under the editorship of Dr. Richard F. Mould, formerly Director of Medical Physics at Westminster Hospital and now with Nucletron International B.V. as their International Marketing Manager.

IOP and IOMP have agreed that the Medical Science Series should become an official book series of the

Continued on page 18

Continued from page 8

- (iii) The reference source should be measured every time the chamber is used to calibrate the short half life sources. When appropriate, the measurement should be corrected for decay of the reference source.

When several small sources such as I^{125} or Ir^{192} seeds are used for a volume implant, the total activity of the batch should be known within 5% and the activity of individual sources should not differ by more than 15%.⁴

Wire sources should be checked to ensure that the linear activity is uniform within $\pm 5\%$; bending of wire during use can cause small areas of low linear activity.¹⁰

D4. Beta-Ray Ophthalmic Applicators (e.g. $Sr^{90}Y^{90}$)

Surface dose rates are specified in mGy/sec. Special equipment is necessary to check the dose rate but relative measurements can be obtained with film and TLD.

IV. Storage of Sealed Source

Clean sources should be kept in a locked, radiation shielded safe designed to allow the safe visualisation of sources: it should be compartmentalised to permit easy access for removing individual sources and for carrying out stock checks. The storage safe or container should be swab tested annually.¹⁴ Any radioactive contamination found should be removed and its source of origin identified.

A detailed inventory of the number, type and activity of sources in the store must be kept as well as details of sources being used in patients; the time of insertion and removal must also be recorded.

An audit should be carried out at monthly intervals for every source in storage or in use.¹² In the UK an independent audit should be made annually by a senior person nominated by the employer.¹⁵

When there is a large number of long lived sources, it is helpful to use a display board which has movable markers corresponding to the location of each source: this provides a visual display of where sources are at any given time. Alternatively, software can be developed and used to display this data on a PC.

Lead carrying pots should be monitored after transfer of sources to ensure that all sources have been removed.

V. Preparation of Sources and Applicators For Clinical Use

Radioactive sources should not be issued or used clinically without a written request from an authorized person: transfer of the source(s) should be recorded.

Manipulation of sources should be with long, low pressure forceps to avoid mechanical damage. Forceps should be monitored and cleaned after use.

Wire sources should be cut only with an appropriately designed cutter: scissors should never be used. A jagged cut releases radioactive fragments. Wire sources with cut ends should be sealed in plastic tubing before inserted into body tissues. The tools used to prepare wire sources (cutters etc.) should be tested for contamination at least twice a year.¹²

When necessary, sources should be sterilized before clinical use. The efficacy of the process must be checked. The source manufacturer should be consulted about the effect of sterilization on source integrity: the sterilization process must not be detrimental to the containment of the radioactive source. Sources such as caesium needles and tubes should not be exposed to temperatures above $180^{\circ}C$.¹⁵

Some brachytherapy techniques make use of empty applicators, needles, or catheters into which the sources are loaded. These devices should be checked before and after use to ensure that they are mechanically sound.

VI. Treatment Planning, Localization and Dose Calculation

The aim of treatment planning is to administer the radiation so that the absorbed dose in the target volume is within 5% of the prescribed dose while at the same time the dose to surrounding normal tissue is minimized.

Aids to planning procedures include the classical methods of Manchester¹⁶ and Paris¹⁷: there are also available computer calculated dose planning tables by a number of authors.^{18 19 20} In relation to quality assurance the following points are significant:

- (i) The precision with which a particular dosimetry system predicts a dose distribution depends upon compliance with the underlying rules and principles upon which the system is based. It is not always possible to fulfill these requirements and the dose delivered must be calculated on the basis of the actual source arrangement.
- (ii) To calculate the dose distributions, radiographic localization of the implanted (inserted) sources is necessary: the precision of the method used should be measured for each type of technique. The accuracy of the reconstruction program must be checked. A phantom can be used for such an evaluation and it is useful for the program to have provision for internal checks such as comparison of calculated length versus actual length and longitudinal position calculated from AP view versus the same positions calculated from lateral view. The accuracy of source localization reconstruction techniques has been evaluated by Slessinger and Grigsby.²¹ Methods which use orthogonal radiographs were found to be accurate within 2mm.

Continued on page 14



TWO PROFESSIONALS

LEAVING NOTHING TO CHANCE

Radiology professionals don't like unnecessary chances. So, when it comes to shielding block cutters, most doctors, technologists and administrators rely on Huestis.

More Huestis Styro-formers are in use than all other shielding block cutters combined, and Huestis is the leading supplier of block cutting accessories and supplies.

Why? Styro-former's incomparably rigid box frame enables consistently true cutting. Other frames just don't meet the Huestis standard.

And Huestis professionalism. We're businesslike, timely and dependable –

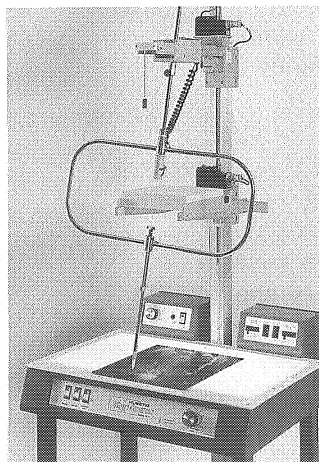

**The Huestis Styro-former,
with Pushbutton Powerlift & Booster**

exactly what you need and what you'd expect from the industry leader.

Only the Huestis Styro-former block cutter, for example, carries the UL label. And Huestis offers a 2-year warranty.

If you haven't taken a good look at Huestis lately, contact us about the Styro-former Booster and Pushbutton Powerlift options, both available on new and retrofitted machines.

And ask about our "Urgent Delivery" policy of shipping supplies.

Call, and you'll learn why radiology professionals depend on Huestis, leaving nothing to chance.

HUESTIS

Huestis Machine Corporation

Buttonwood St. Bristol, RI 02809 USA Phone (401) 253-5500
(800) 972-9222, (800) XRAY222 Fax (401) 253-7350 Telex 952128

- (iii) In computer calculations the algorithm used should be evaluated. Some algorithms provide accurate data in regions near to the source and are less precise at greater distances. The characteristics of the algorithm should be investigated at various distances (typically 20, 50 and 80mm) either by independent calculation or by experimental measurement. Dose algorithms should calculate doses to within a few percent of the true dose at distances up to 50mm from the source. The algorithms used should allow for scatter absorption in tissue, absorption in the source, source encapsulation, absorption in the applicator or catheter, and any special shielding devices.

Dosimetry techniques should be evaluated before being used clinically and checked after software changes or machine fault rectification. Particular care should be taken to ensure consistency between the physical coefficients used in the dosimetry program and those used to specify source strength. The user should confirm that the programmed decay corrections are accurate.

- (iv) In estimating the overall accuracy of a particular technique some estimation should be made of the likelihood of source displacement during the course of treatment.

In practice, the positions of removable sources should be ascertained as soon as possible after their placement and should be checked during treatment. Any occurrence of source movement must be reported to the clinician in charge of the patient so that suitable corrections can be made.

- (v) It is good practice for all treatment dosimetry computations to be checked independently by a second person.

VII. Removal of Sources From Patients

When sources have to be removed from a patient, either at the end of treatment or sometimes when a source has been inadvertently displaced, they should be removed carefully to avoid patient trauma and source damage. Sources should be placed in a shielded container lined with a plastic pot containing bactericidal fluid. The patient must be checked with a GM monitor to confirm that all the sources have been removed.

As soon as possible the sources should be returned to the laboratory/store where they should be counted, checked for damage and stock records completed. Only after it is known that all sources have been returned should the patient be allowed to leave hospital.

VIII. Source and Applicator Cleaning

It is necessary to clean sources that have come into contact with body tissues before they can be stored and/or re-used. Immersion in bactericidal fluid on removal from the patient prevents biologically active material reaching the laboratory store. Source manufacturers should advise about cleaning procedures: damage to source capsules can occur as a result of chemical attack if inappropriate cleaning agents are used.

Sources such as caesium needles and tubes must be inspected after cleaning for abrasions, signs of wear or damage. If there is either:

- i) deep scratching of the surface
- ii) blunted trocar point
- iii) illegible engraving
- iv) blocked or damaged eyelet
- v) or any other defect or cause for concern

the device should be returned to the manufacturer.

Whenever evidence of damage or possible encapsulation failure is noticed, swab and leakage tests must be made to determine whether the radioactive material is leaking.

Wire sources that are to be re-used should be inspected for damage and re-measured prior to use.

After removal from the patient, applicators (catheters etc.) should be immersed in bactericidal fluid, cleaned and inspected for damage.

Radioactive sources are often inserted into patients in sealed plastic tubing, plastic applicators or, as in the case of most afterloading techniques stainless steel tubes. It is good practice to check these source carrying devices for radioactivity with a GM monitor after each use.

IX. Additional Checks For Automatic Afterloading Equipment

In addition to the tests and measurements described in the foregoing section relating to radioactive sources, the use of afterloading equipment necessitates machine function and safety checks:

A. Machine Function

The requirements for the safety of remote-controlled automatically - driven gamma-ray afterloading equipment are specified for machines which give air kerma rates up to 500 mGy per hour at 1m in IEC 601-2-17.⁷

In addition to functional checks and maintenance, this standard draws attention to the need for accompanying documents concerning the importance of:

- (i) checking interlocks
- (ii) checking the security of couplings and connections

For Quality Assurance
in Radiation Therapy...

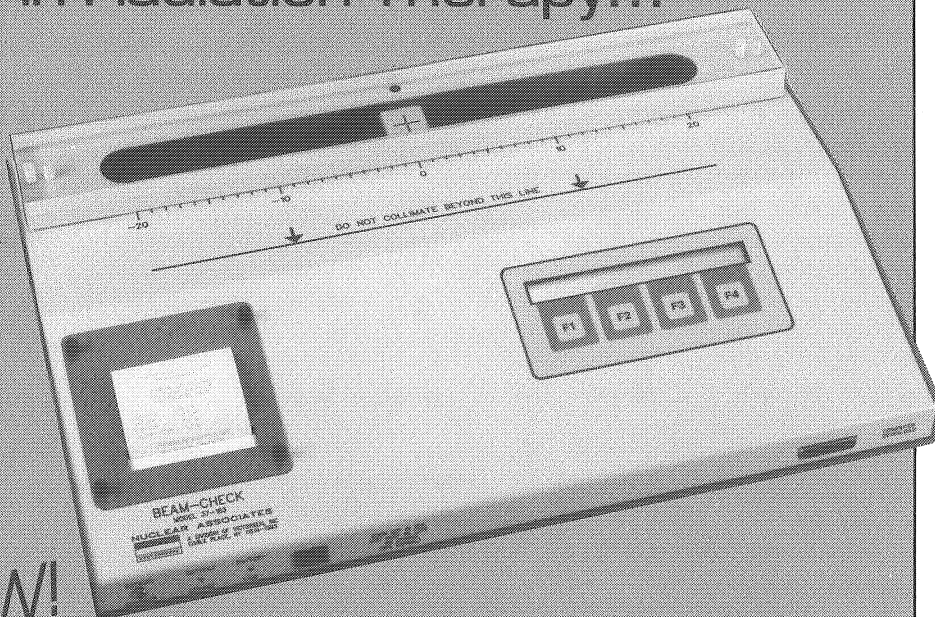

NEW!

BEAM-CHECK™

Light & Radiation Field Analyzer

TRANSVERSE RADIATION FIELD SCAN

Date 2/1/89 Time 1:21 AM
Scan # Room 000 Test 0
Mode = COMPLETE Star Size = 1mm
SDP = 2 Field Size = 0

Operator name: _____
Buildup: _____ Dose rate: _____
Photon: _____ MU Electron: _____ MeV

Field Width 273 mm
Left Edge -135 mm
Right Edge 138 mm
Flatness 8.8 %
Symmetry 1.8 %
Penumbra left 7 mm
Penumbra right -7 mm
Coincidence left -8 mm
Coincidence right -1 mm

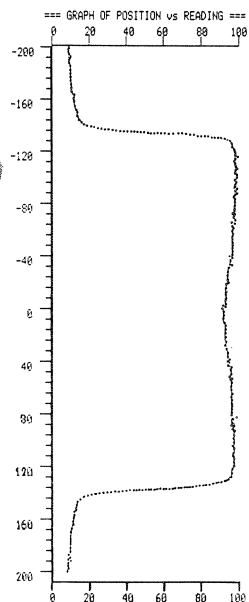

Printed Output of Radiation Field Scan

TRANSVERSE LIGHT FIELD SCAN

Date 2/1/89 Time 1:15 AM
Scan # Room 000 Test 0

Field Width 266 mm
Left Edge -127 mm
Right Edge 139 mm
Crosshair Offset 6 mm

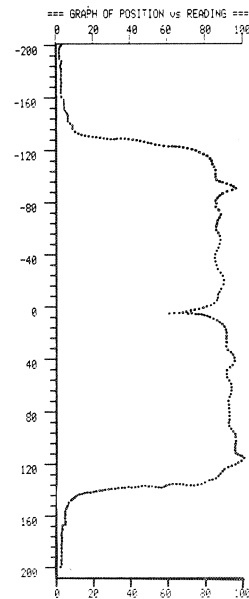

Printed Output of Light Field Scan

- Checks light field and radiation field coincidence.
- Analyzes radiation field for flatness, symmetry, and penumbral size.
- Built-in graphics printer provides hardcopy outputs of scan information.
- Single axis diode scanner.
- Self-contained, no cables to attach.

*Developed in collaboration with Lawrence E. Reinstein, Ph.D.,
Radiation Oncology Department,
State University of New York at Stony Brook.

For more information, request Bulletin 430-33

NUCLEAR ASSOCIATES



Division of VICTOREEN, INC.
100 VOICE ROAD • P.O. BOX 349
CARLE PLACE, NY 11514-0349 U.S.A.
(516) 741-6360
FAX (516) 741-5414

TM, Victoreen, Inc.

- (iii) need for special procedures after a failure of a controlling timer
- (iv) recommended procedure in the event of failure of source to return to the storage container
- (v) measuring the transit dose
- (vi) limitations of channels and source applicators
- (vii) asymmetric source applicator checks

The quality assurance programme should ensure compliance with these requirements and must include all functional tests recommended by the manufacturer.

The user should be satisfied that the radioactive sources are positioned and sequenced properly. This might make it necessary to radiograph and autoradiograph the source sequence prior to use or view the source with CCTV.

Controlling timers should be checked after each service and at least annually. Timers must have a mean average error not exceeding 1%.⁷

The source travel time should be determined for each channel and the air kerma at 20mm from the axial centre of the source applicator and at 1m from the centre of the axial centre of the channel measured.⁷ An evaluation must be made to ascertain whether an allowance should be made in the dose calculations on account of source transit.

B. Facility Testing

Room protection should be such as to reduce dose levels in surrounding areas to acceptable limits and must be checked at commissioning and after structural alterations.

Door interlock checks should be made before treatment starts. There should be an independent audible GM probe and monitor mounted inside the treatment room with an additional monitor mounted at the control console. The probe should be located so as to indicate the radiation dose rate in the treatment room and to confirm that an exposure is taking place. The system should be tested each time the machine is used.

Outside the treatment room there should be a radiation dose rate monitor for emergency use; this should be tested monthly.

C. Machine Failure

Emergency procedures should be tested regularly and posted in a prominent place. It is good practice to simulate a source return failure at regular intervals. Equipment should be available for removing and storing a radioactive source in the event of source return failure.

REFERENCES

1. Pierquin, B., Wilson, J. F. and Chassagne D. (1987). Modern Brachytherapy, Masson Publishing (USA: New York).
2. Godden, T. J. (1988). Physical Aspects of Brachytherapy Medical Physics Handbook 19, Adam Hilger (Bristol and Philadelphia).
3. Trott, N. G. (1987). Radionuclides in Brachytherapy: Radium and After. Brit. J Radiol Suppl. 21.
4. ICRP Publication 44 (1985). Protection of the Patient in Radiation Therapy. Annals of the ICRP Pergamon Press (Oxford, New York). Vol. 15, 2.
5. Jones, C.H. (1988). Quality Assurance in Gynaecological Brachytherapy in Dosimetry in Radiotherapy Proc. IAEA Symposium (Vienna, 1987) 1, 275-290.
6. Radiation Protection in Radiotherapy (1986). IPSM Report 46, Eds.: A. L. McKenzie, J. E. Shaw, S. K. Stephenson and P. C. R. Turner (IPSM London).
7. International Standard IEC 601-2-17 (1989). Medical Electrical Equipment Part 2: Particular Requirements for the Safety of Remote-Controlled Automatically-Driven Gamma-Ray After-loading Equipment.
8. British Commission on Radiological Units (BCRU) (1984) Br. J Radiol 57, 941.
9. Williamson, J. F., Khan, F. M., Sharma, S. C. and Fullerton, G. D. (1982) Methods For Routine Calibration of Brachytherapy Sources. Radiology 142, 511-516.
10. Bernard, M., Guille, B. and Duvalet, G. (1975). Mesure du Debit D'exposition Lineique Nominal des Sources a une Dimension, Utilisees en Annetherapie. J Radiol Electrol. 56, 785-790.
11. Meertens, H. (1984). A Calibration Method For Selectron LDR Sources in Brachytherapy 1984. Proc. 3rd Int. Selectron Users' Meeting 1984. Ed.: R. F. Mould (Nucletron Trading BV). 59-67.
12. Quality Assurance in Radiotherapy (1988). Institute of Radiation Hygiene and World Health Organization (WHO; Geneva).
13. Ezzell, G. (1989). Calibration Intercomparison of an ¹⁹²Ir Source Used For High Dose Rate Remote Afterloading. Activity Vo. 3. 13-15.
14. AAPM Report 13 (1985). Physical Aspects of Quality Assurance in Radiation Therapy. American Institute of Physics.
15. Guidance Notes For the Protection of Persons Against Ionising Radiations Arising From Medical and Dental Use (1988). HMSO (UK).
16. Parker, H. M. (1967). In Radium Dosage. The Manchester System. Ed.: W. J. Meridith, Second Edition, E. and S. Livingstone (Edinburgh and London).
17. Pierquin, B. (1964). Precis de Curietherapie. Masson (Paris).
18. Laughlin, J. S., Silver, W. M., Holodny, E. I. and Ritter, F. W. (1963). A Dose Description System For Interstitial Radiation Therapy. Am J Roetengenol 89, 470-490.
19. Young, M. E. J. and Batho, H. F. (1964). Dose Tables For Linear Radium Sources Calculated By An Electronic Computer. Brit J Radiol 37, 38-44.
20. Hall, E. J. Oliver, R. and Shepstone, B. J. (1966). Routine Dosimetry With Tantalum 182 and Iridium 192 Wires. Acta Rad Therapy 4, 155-160.
21. Slessinger, E. D. and Grigsby, P. W. (1989). Verification Studies of 3D Brachytherapy Source Reconstruction Techniques: In Brachytherapy 2. Proc. of the 5th Int. Selectron Users' Meeting 1988. Ed.: R. F. Mould (Nucletron International BV) 130-135.

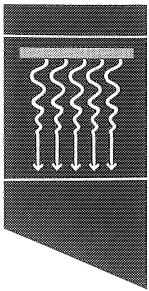

Quality
Control in
Radiotherapy

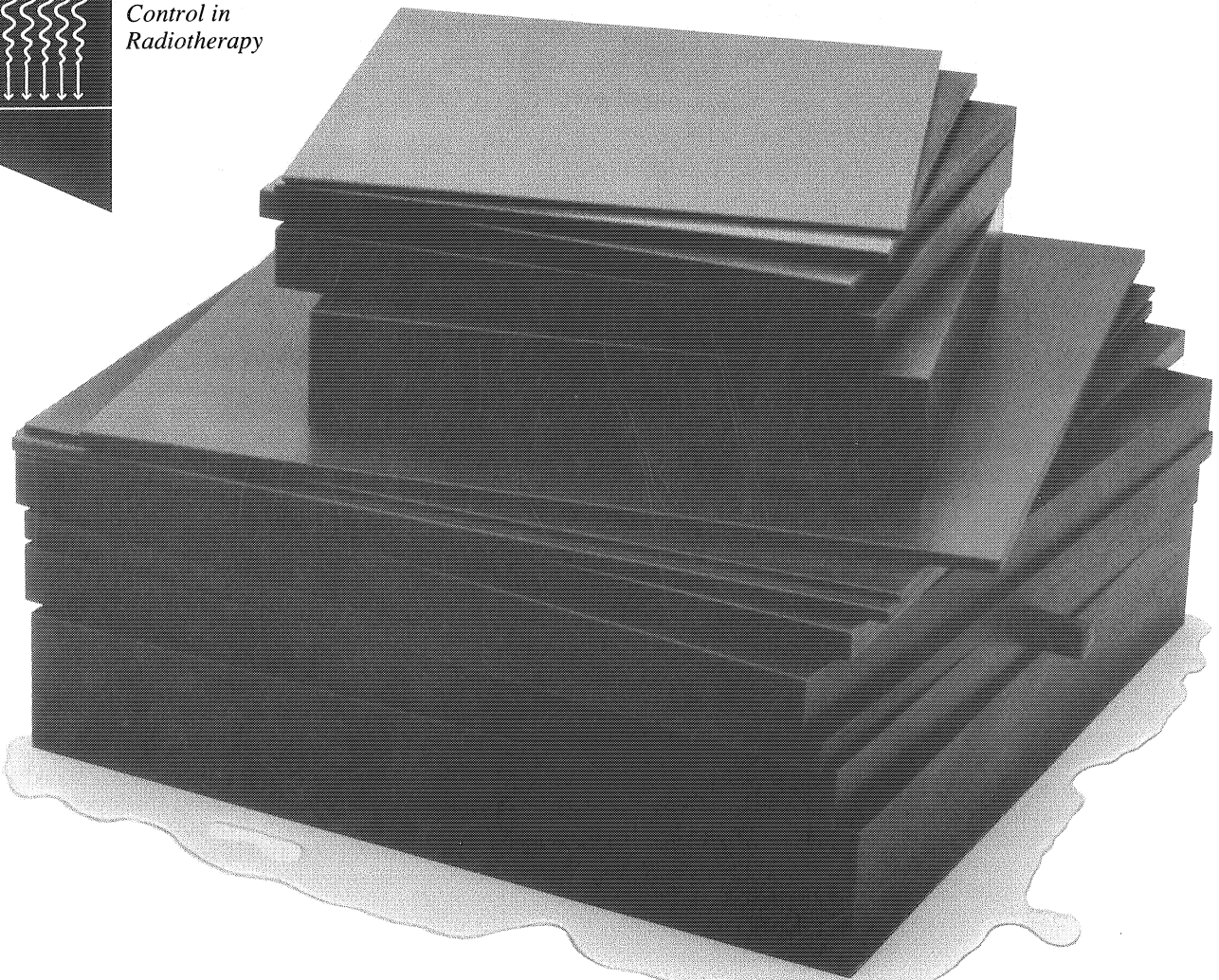

RMI Solid Water™ Stacks Up!

Patient safety. Calibration accuracy. Positive treatment outcome. In radiotherapy, nothing is more important. And for radiotherapy equipment calibration, nothing stacks up like Solid Water™ by Radiation Measurements, Inc. (RMI®).

Solid Water™ stacks up for ease of use...

- Eliminates the time and expense required by water tank tests
- Measurements made with Solid Water™ agree with those made at an equal depth of water to within 0.5%
- Superior to other plastic water substitutes — no dose errors due to charge storage, no need to measure density or to correct for depth or SSD



RMI's Solid Water™ can be customized to fit your ion chamber.

©1989, Radiation Measurements, Inc.
A Lescrenier company

Solid Water™ stacks up for flexibility...

- Standard and custom slab sizes and thicknesses available
- Position your ion chamber at any equivalent water depth

No matter how you stack it, RMI Solid Water™ means easy, accurate calibration. For calibration you can trust, call the Solid Water™ experts. Call RMI today.

1-800-443-5852

In Wisconsin, call (608) 831-1188

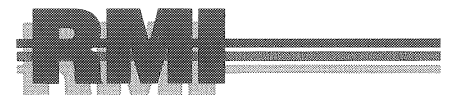

Radiation Measurements, Inc.
7617 Donna Drive, Box 327
Middleton, WI 53562-0327
TLX: 510-601-9035

Beijing International Congress On Medical Radiation Physics, May 27-30, 1990

Oskar A. Chomicki

Secretary-General, Polish Society of Medical Physics

Many institutions participated in the organization of the Congress and several contributions, among them that of the Edmondson Cancer Research Fund of the Eastern Virginia Medical School, were generously provided.

The BICMRP, first of its kind in 40 years, was sponsored by the Chinese Association of Radiation Physics, the Chinese Society of Medical Physics and the International Affairs Committee of the American Association of Physicists in Medicine.

Fifty-seven papers and over 30 posters were presented. The total number of participants was 226, of which 56 came as foreign guests from countries such as the U.S.A., U.K., France, Italy, Belgium, Canada, India, Switzerland, Taiwan, Hong Kong and Poland and 12 were young Chinese medical physicists preparing to leave for study abroad.

In his inaugural lecture Professor Hsienchi Ku, M.D., President of the Chinese Society of Radiation Oncology from the Cancer Institute (Hospital) of the Chinese Academy of Medical Sciences, Beijing, described the present status of Radiation Oncology in China. Before 1949, radiation oncology practically was non-existent: there were only one Radium Institute in Shanghai and one radiotherapy clinic in Beijing with a few hundred milligrams of Ra, a few X-ray therapy machines and a few radiologists. Soon after 1949, cancer hospitals and research institutes became established in various provinces, and later the Chinese Society of Radiation Oncology was formed. As of 1988, there are in China 264 radiation oncology departments or clinics, 1,715 doctors, 180 radiation physicists, 76 radiobiologists and 410 technicians. The radiation oncology equipment include 71 linear accelerators, 239 telecobalt units, 224 deep X-ray machines, 100 simulators and 78 afterloading units. Nationwide programs for training medical and physics personnel involved in radiation oncology have been set up, as well as one-year postgraduate and refresher courses organized under the auspices of the Department of Science and Technology of the Ministry of Public Health and the Society of Radiation Oncology. However, there is still need for qualified personnel, specially physicists, as the demands posed by cancer patients in a country with the population of over 1 billion people are quite heavy.

The problem of human resources in medical physics was also stressed by Dr. U. Madhvanath of India. In that country, the cancer incidence is 800 per million per year, of which 50-60% require radiation treatment, whereas there are only 161 therapy units in 104 centers although the demand would be for at least 800 units.

It would be next to impossible to give fair account to all the papers presented. There were sessions covering most topics in Medical Radiation Physics including radiation therapy, dosimetry, hyperthermia, diagnostic radiology, nuclear medicine, photon emission tomography and quality assurance.

On the last day of the Congress one session was devoted to brachytherapy, and the other to total skin irradiation. Dr. U. Madhvanath of Bhabha Atomic Research Centre, Bombay, India presented a manual afterloading intracavitary applicator kit suitable for developing countries because of its low price (\$4,000) and simple design. Several papers dealt with total skin electron therapy for mycosis fungoides.

More than 30 posters exhibited during the Congress covered almost all the subjects dealt with in oral presentations.

During the Congress, the organizers arranged for a most interesting tour of the Cancer Institute (Hospital) of the Chinese Academy of Medical Sciences in Beijing.

The Institute includes many departments dealing with bio-chemistry, pathology of cancer, etc. and provides for some postgraduate courses for doctors. Its main aim, however, is to diagnose and treat cancer patients from all over China, of whom 600 stay in the hospital and many more are accepted on an out-patient basis, all of them being looked after by the personnel of 1,400. The Department of Radiation Oncology is headed by Professor Wei-bo Yin.

The patient throughput is about 300 per day, of which 200 are out-patients and the department has at its disposal 3 linacs, 1 betatron and 1 orthovoltage X-ray machine.

For diagnosis, the department has one NMR unit, CT scanners and Anger cameras.

There is a great need to share scientific and technical knowledge with medical physicists throughout the world and I am sure the Beijing International Congress on Medical Radiation Physics has done a very good job in promoting this noble aim.

Continued from page 11

IOMP. In return, copies of important Hilger titles will be distributed free of charge to medical physicists in over 90 developing countries throughout the world.

The Adam Hilger Medical Science Series

A message from the Series Editor, Dr. R. F. Mould

Our aim in developing the Medical Science Series has been to promote the publication of books describing the applications of the physical sciences and mathematics in the diagnosis, treatment and prevention of human disease. We endeavour to commission books that will be of practical, everyday use to the medical physicist, biomedical engineer, radiologist or radiotherapist, as well as seminal text that address issues at the borders of current knowledge.

Approaches from aspiring new authors are always welcome. If you believe you might have something to contribute, please feel free to contact me directly at 2 Elmfield Way, South Croydon, Surrey, CR2 0ED, UK, Tel: 081 657 8976, Fax: 081 651 3624. Alternatively, you may wish to contact the publisher's editor, Mr. Sean Pidgeon, who is based in IOP's North American editorial office: IOP Publishing/Adam Hilger, 1411 Walnut Street, Suite 200, Philadelphia, PA 19102, USA, Tel: (215) 569-2988, Fax: (215) 569-8911.

We look forward to receiving your support. Remember that IOP is a not-for-profit organization; all profits from its publishing activities are channelled back into the science community that it serves.

PANASONIC TLD DOSIMETRY. THE MULTIPLE-CHOICE ANSWER.



Wide range of dosimeters.



UD-716 automatic reader with glow curve display.



UD-710 automatic TLD reader with UD-730 automatic changer.

Move up to TLD dosimetry and questions arise.

Who can meet your needs for whole body *and* extremity badges, *and* readers, *and* automated integrated systems?

Who's the technological innovator and market leader? Top choice of the nuclear power industry and U.S. government labs? Whose equipment makes it easy to pass NVLAP and DOELAP certification?

So many questions, but just one answer. Get it by calling 1-800-848-3979. Or write Panasonic Industrial Company, Radiation Measurement Systems, Two Panasonic Way (7E-4), Secaucus, NJ 07094.

Panasonic®
Radiation Measurement Systems

THER-A-CROSS/BACK POINTER

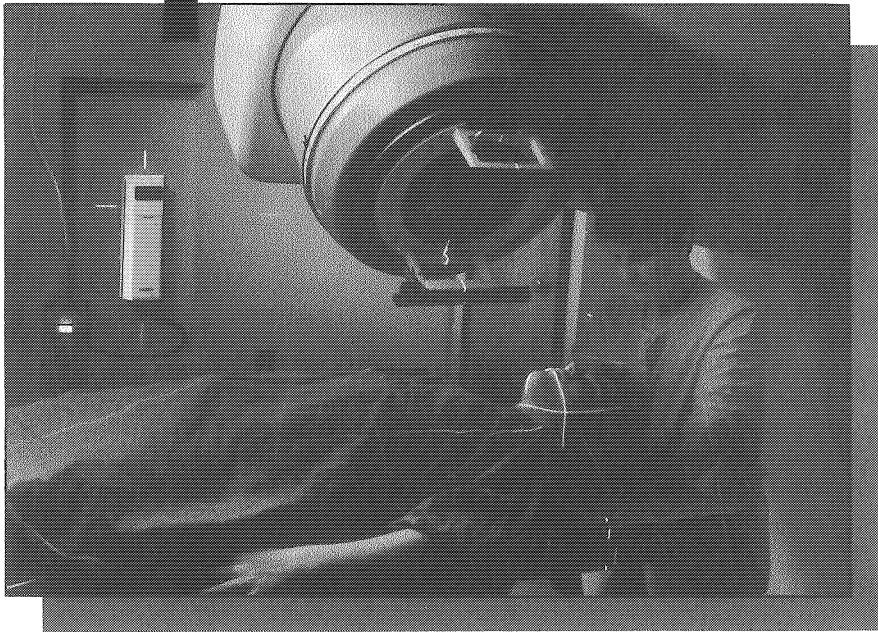

**A Fully Integrated
Precision Laser
Patient Alignment System
with Accuracy and
Efficiency Built-in.**

No idle claim.

The combined THER-A-CROSS™/ FIBER OPTIC BACK POINTER™ system creates a complete envelope of intersections in which you can have full *confidence* of precise positioning and *assurance* of simpler set-ups of patients.

Of equal importance, the THER-A-CROSS/BACK POINTER system has been designed with particular emphasis placed on increased *productivity* and *cost containment* to maximize department time/expense efficiency.

The four laser THER-A-CROSS provides horizontal, transverse, and sagittal beams that identify the therapy axis and define the exact isocenter for patient positioning. The BACK POINTER optically defines the critical beam exit and eliminates cumbersome calculations or mechanical devices.

Avoid the uncertainty of add-on or mix-and-match components. Select a fully compatible, cost effective patient alignment system that assures single source responsibility for application analysis, specifications, installation, and service. All backed with a full warranty, complete compliance with CDRH regulations, and a twenty year history of Gammex dependability.

Call toll free 1-800-GAMMEX-1 or write for descriptive, technical Bulletins 22 and 24.

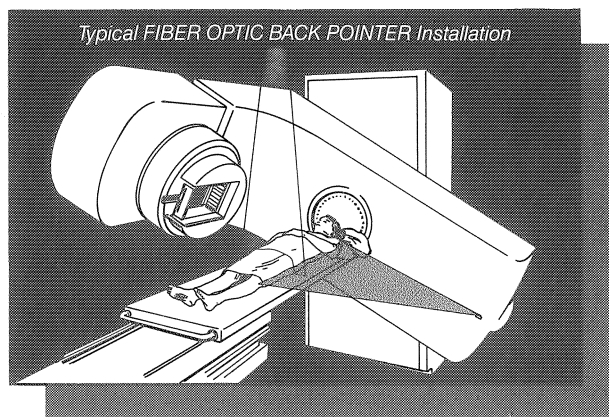
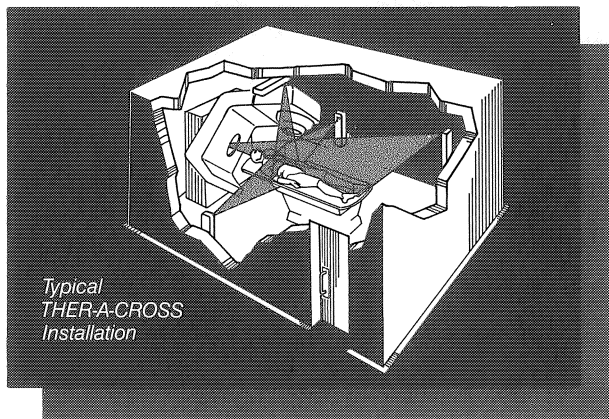

GAMMEX LASERS™